

Explanation To Terminology And Guidelines

Preface	188
Chapter 1 The Basic Terminologies Of Relays	188
1. Contact Parameters	188
2. Characteristics Parameters	189
3. Coil Parameters	191
4. Ordering Code	191
5. Outline Dimensions, Wiring Diagram And The Size Drawing Of The Mounting Holes	191
6. Characteristic Curves	192
7. Monostable, Latching And Polarized Relays	192
Chapter 2 The Principles Of Selecting The Relays ---	193
Chapter 3 Precautions For Applying The Relays	197
Chapter 4 Ordering Code	212
Chapter 5 Quick Zoom Table For Reasons For Failure	213



PREFACE

1 Principles

K K A and its affiliates have made every effort to guarantee the accuracy of instructions and specifications. Still, errors may occur. Therefore, KKA and its affiliates reserve the right to make any modification to the instructions and specifications.

K K A and its affiliates claim only the responsibility of the clearly confirmed experiment clauses and condition of sale as well as the application condition and test results stated in particular specifications. We disclaim any assumptions or implications of any of our specifications and instructions.

Given the impossibility of defining all the requirements of all the relays in every application, users shall select relays accordingly and re-check through careful evaluation, or turn to K K A and its affiliates for technical support if necessary. Users shall take full responsibility for relay selection.

2 Definition and Classification

Relay is a kind of component by which when the input is reached a certain value, one or more outputs will produce the scheduled changes.

For electromagnetic relay, SSR and combined relay, it can be simply understood in the following way: it is a switch by which in the input end the speculated electrical signals are applied, the output end makes or breaks the controlled circuit.

Automotive relays are designed for automotive application usage. It could be categorized by many different ways. Basing on terminal arrangement and different functions, automotive relays could be divided into below 3 types:

- PCB automotive relay: Automotive relays that will be used by soldering onto PCB board.
- Plug-in automotive relay: Automotive relays that will be plugged into specific sockets. The terminal widths are in 4 different types: 2.8mm, 4.8mm, 6.3mm, 9.5mm. The terminal layout could be divided into ISO category (Micro ISO, Mini ISO, Power Mini ISO) and 280 category (Ultra 280, Micro 280, Mini 280).
- Combined automotive relay modules: Relay modules combined PCB automotive relays together with other logic electric circuits to fulfill certain functions.
- Flow Relay: An Electromagnetic relay which is assembled with hard connection, and maximum rated switching current is above 80A.

This article states the basic information about the automotive relay, and also lists the principles of selecting them and cautions about applications.

Generally the parameters in the instructions in the catalogue are the measured initial values under the standard, which are as follows, unless otherwise stated.

- 1) temperature: $23^{\circ}\text{C} \pm 5^{\circ}\text{C}$
- 2) relative humidity: 25% to 75%RH
- 3) air pressure: 86kPa to 106kPa

Generally the drawings stated in the catalogue is the first quadrant projection way as shown in figure 1, unless

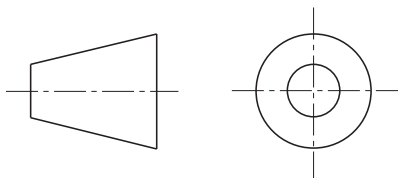

Figure 1

CHAPTER 1 THE BASIC TERMINOLOGY OF RELAYS

1 Contact Parameters

- 1.1 Contact arrangement: The arrangement form for relay contacts, the normal contact arrangement forms have been listed in sheet 1.

GUIDELINES OF AUTOMOTIVE RELAY

Table 1

Name	Symbol	Alphabet Letter	
		China	Others
Normally Open Contacts		H	A(or NO)
Normally Closed Contacts		D	B(or NC)
Change-Over Contacts		Z	C(or CO)
Double Normally Open Contacts		SH	U(or 2NO)
Double Normally Closed Contacts		SD	V(or 2NC)

1.2 Contact resistance is the total resistance between the contacts, the terminals and spring jointed with contacts, generally shown in $m\Omega$, the contact resistance is measured using the voltage-drop method as shown below. Normally, under the circumstances of load application larger than or equal than 1A, The testing current is 1A 6VDC.

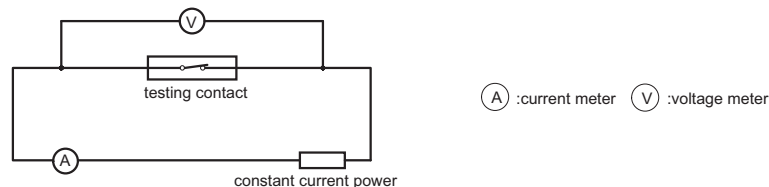

Figure 1

1.3 Contact voltage drop generally is, in the load circuit, the total voltage drop between contacts, springs jointed with contact and the terminals. It is generally described in the voltage drop value in the regulated current, for example 50mV (measured in 10A).

1.4 Contact material is the material used in contacts and generally shown in chemistry formula, for example, $AgSnO_2$ represents $AgSnO_2$ alloy contact. The materials used in the Automotive relay, its characteristics and its application environment can be seen in 1.2 'Contact material' in chapter 2 'the principles for selecting relays'.

1.5 Contact rated load generally refers to the load which the contacts can switch reliably under the certain regulated conditions. Generally it is shown as the combination of the voltage and the current.

1.6 Max. switching voltage is the maximum load voltage which the contacts can switch. In general application, this voltage value shall not be surpassed, or the relay endurance will be reduced, it may lead to relay failure.

1.7 Max. switching current is the maximum load current which relay contacts can switch. In general application, this voltage value shall not be surpassed, or the relay endurance will be reduced, it may lead to relay failure.

1.8 Maximum continuous current is the load current the relay contact could bear. The maximum continuous currents the relay could bear are quite different under different environment temperature. Please don't exceed this value for real application, otherwise the relay may be overheat and burnt.

1.9 Mechanical endurance: refers to the operations that the relays without load or load which do not lead to failure under the rated voltage, normally switch in the specified. Generally it is shown in operations.

1.10 Electrical endurance: generally refers to the operations that the relay can normally switch when the specified load is applied on the contacts and the relay is placed in certain specified environment. Generally it is shown

1.11 Min. applicable load generally is the minimum load that the relay can switch reliably. According to ON-OFF frequency, environment and the difference of the required contact resistance, the reliability of Min. applicable load is different. Under the different conditions, the min. load to be switched is different. If the maximum load can not meet the related requirements in the relay specifications, please contact us for more technical support.

1.12 Hard Connection: refers to the mechanical connection of two rigid objects by the ways of soldering or riveting.

2 Characteristics Parameters

2.1 Insulation resistance is the impedance when the conductors insulated with insulating material are applied to voltage and it is generally shown in " $M\Omega$ ". The speculated voltage discribed above are generally 500Vd.c..

GUIDELINES OF AUTOMOTIVE RELAY

- 2.2 Dielectric strength** is the voltage value when, within the speculated time, the conductors insulated with insulated material are applied to the voltage and the leakage current is less than the speculated current. The certain voltage above generally is the effective value of AC voltage and unless otherwise stated, the leakage current is generally less 1mA.
- 2.3 Operate time** refers to, with the Monostable relay in the released state, The time from the application of the specified coil voltage to the contact circuit switching its state. It does not include any bounce time, and expressed in "ms". Seen in figure 3.
- 2.4 Release time** refers to, with the Monostable relay in the operation state, The time from the removal of the specified coil voltage to the contact circuit transiting its state. It does not include bounce time and expressed in "ms".
- 2.5 Reset time** . For the bi-stable relays in action state, the time from applying the specified coil voltage to the last switching contact circuit state, excluding the bounce back time. Seen in figure 3.
- 2.6 Bounce time** For a contact that is closing or opening its circuit, the time from the moment when the contact circuit is first closed or opened to the moment when the circuit is finally closed or opened, generally expressed

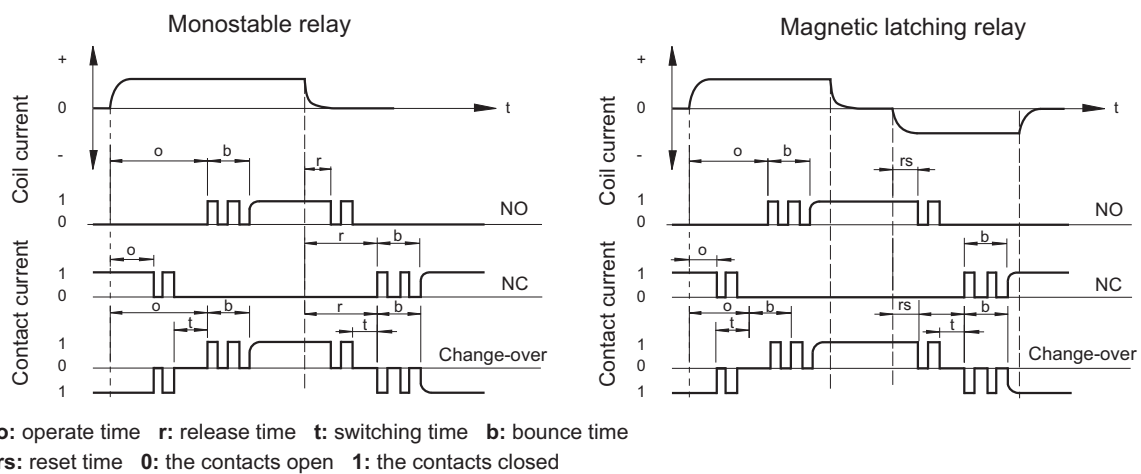

Figure 3

- 2.7 Switching frequency** refers to the cycling times of the operation and release in united time.
- 2.8 Duty cycle:** refers to the in the ratio of incentive time to the whole cycle time in an intermittent, continuous or short-term working system.
- 2.9 Ambient temperature** refers to the temperature in which the relay can normally be applied and it is generally expressed in the range of temperature.
- 2.10 coil temperature rise** refers to the temperature that the coil rises by after the temperature become stable and on the conditions that in the suitable maximum ambient environment the rated voltage is impressed on the coil and the rated load is impressed on the contacts. Generally it refers to the maximum value, expressed inK.
- 2.11 Shock** is divided into shock functional and survival.
- Shock functional**
Shock refers to the acceleration the relay can suffer the shock value under the condition of the NC contact open time and open contact closing time at specified time. Usually it is expressed in the combination of the acceleration value "g" ($1g=9.8m/s^2$) and the duration "ms".
- Shock survival**
refers to the shock value that the relay can withstand without damaging the structure of the relay. It is generally expressed by the combination of "m / S²", acceleration value ($9.8m / S^2 = 1g$) and "ms", which means duration.acceleration value "g" ($1g=9.8m/s^2$) and the duration "ms".
- 2.12 Vibration resistance stability** Vibration refers to the vibration the relay can suffer without causing the closed contacts to open for more than the specified time and the open contacts to close for more than the specified time. Sine vibration is usually expressed in the combination of the vibration "mm" or the acceleration value "g" ($1g=9.8m/s^2$) and the vibration frequency "Hz".

GUIDELINES OF AUTOMOTIVE RELAY

Vibration strength refers to the vibration value that the relay can bear without damaging the structure of the relay. The sinusoidal vibration is generally in the form of the vibration "mm" or the acceleration value "g" ($1g=9.8m/s^2$) and the vibration frequency "Hz".

- 2.13 Humidity** refers to the required humidity in which the relay can reliably work and generally expressed in relative humidity "%RH".
- 2.14 Model Of The Terminals:** the terminals of automotive relays could be divided into three types: PCB type ,Plug-in type and hard connection type . The Plug-in type is with two major dimension categories: ISO and 280.
- 2.15 Weight** Weight of a single relay.
- 2.16 Enclosure type** refers to the protection mode for the relay body. It is divided into enclosed, dust protected, flux proofed, plastic sealed and hermetically sealed. Seen in 3.1 'mode of encapsulation' in chapter 2 'the principles of selecting the relays'

3 Coil Parameters

- 3.1 The rated coil power** refers to the power consumed by the coil when the coil are applied to the rated voltage. Generally for the Automotive relay, it is expressed in W .
- 3.2 Rated voltage** is the voltage applied to the coil in order to make the relay work normally. It is expressed in "V". For the polarized relay, the direction in which the voltage is impressed should be notified.
- 3.3 Action voltage, set voltage** (only applicable to bistable relays) the coil voltage value that makes the relay operate,Usually it is expressed in "V". It is usually the maximum value listed in the instructions.
- 3.4 Release voltage** refers to the coil voltage value released by the monostable relay,It is usually expressed in "V". The minimum value is listed in the instructions.
- 3.5 Reset voltage** The voltage value to reset the bistable relay,It is expressed in "V". The maximum value is listed in the catalogue.
- 3.6 Coil resistance** generally refers to the DC resistance and is expressed in " Ω ". In the catalogue the combination of the nominal value and tolerance is given.
- 3.7 The coil equivalent resistance:** the resistance tested at the coil terminal when the coil is paralleled with peak inverse voltage suppression components. It is normally marked with " Ω ". Usually the combination of standard value and tolerance will be shown on data sheet.
- 3.8 Maximum allowable voltage** refers to the maximum voltage which can be applied to the coil in the certain period of time. It is expressed in V.

4 Ordering Code

Ordering code is a code which is used to ensure the type and the specifications of the relay, which includes the basic information of the relays, such as the type of the products, the coil voltage, contacts arrangement, the enclosure type etc.. The ordering code of HONGFA brand relay can be seen in Chapter 5 "the ordering code".









5 Outline Dimensions, Wiring Diagram And The Size Drawing Of The Mounting Holes

Ordering mark is a mark which is used to ensure the type and the specifications of the relay, which includes the basic information of the relays, such as the type of the products, the coil voltage, contacts arrangement, the mode of encapsulation etc.. The ordering marks of HONGFA brand relay can be seen in Chapter 5 "the ordering marks".

- 5.1 Outline dimensions** describes the drawing of the relay outline size and the mounting space needed by relay.
- 5.2 Wiring diagram** describes the wiring way of the input and output terminals respondent to the terminals of the relays.
- 5.3 The size drawing of the mounting holes** describes the position of the relay terminals and the size of their mounting holes.
- 5.4 Examples**
The examples of the common components can be seen in table 2.

GUIDELINES OF AUTOMOTIVE RELAY

Table 2

Coil	Polarized Coil	Contact	Resistance	Capacitance	Diode	Zener Diode	Bidirectional instantaneous voltage suppression diode	Varistor
								

6 Characteristic Curves

6.1 The curve of maximum bearable load: the demonstration of maximum load the relay could bear.

6.2 The curve of maximum continuous voltage to coil: the demonstration of maximum voltage the coil could bear under different environment temperature.

7 Monostable, Latching And Polarized Relays

7.1 Monostable Relay:

For this relay, the contacts operate when the coil is energized while the contacts will reset when the coil is deenergized.

7.2 Latching Relay:

For this relay, the contacts operate when the coil is energized while the contacts will keep the state when the coil is deenergized. To reset the contacts, the counter-energization will be applied to the single-coil coil or the energization is applied to the double-coil reset coil .

7.3 Polarized Relay:

The switch of the contact state is dependent on the polarity of the energized voltage in the terminals of the coil. Part of the monostable relays and all the magnetic latching relays belong to polarized relays.

The basic circuit and operating wave of the several common relays can be seen in table 3.

Table 3

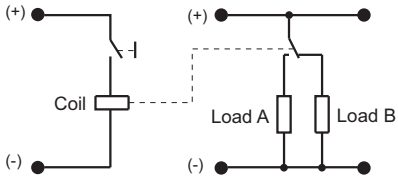
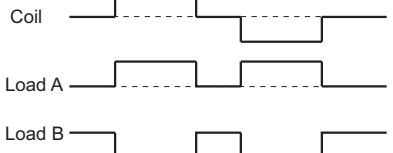
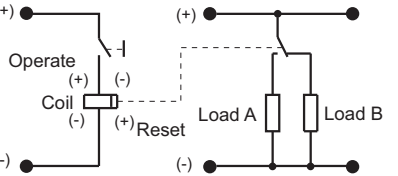
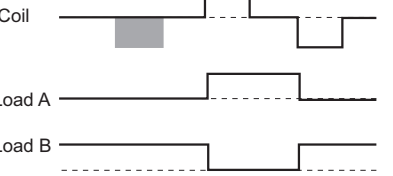
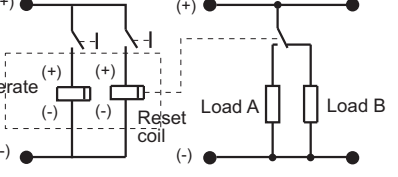
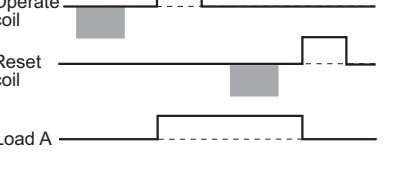
Non-Polarized Monostable		
Single-coil Latching		
Two-coil Latching		

Notes: The voltage with the correct polarity is required to impress on the coil of polarized relays or the relays will not work, as shown in the shaded area in the figures above.

CHAPTER 2 THE PRINCIPLES OF SELECTING THE RELAYS

In order to correctly select relays, the customers need know about the characteristics of the relays to ensure whether these characteristics meet with the practical requirements. It will be more reliable if these characteristics can be tested in the practical environment. The principles of selecting the relays can be seen in table 4. In table 4, in the column "must be confirmed" the item with the mark is confirmed and a type of relay can be selected. If there is further requirement, the correspondent items with the mark are required to be further confirmed.

Table 4

Item		The considered points	Confirmed	Reference	Influence factors
Contact	Contact load	Size (current or voltage), Type (inductive or resistive)?	<input checked="" type="checkbox"/>		<ul style="list-style-type: none"> ● the ambient temperature ● as for AC load, is the operation and the load synchronous or not ● Does the contact material match the load?
	Contact arrangement	NO or NC or switching? how many pairs of the contacts?	<input checked="" type="checkbox"/>		
	Maximum continuous current and working time	Influence of switching frequency and duty cycle?	<input checked="" type="checkbox"/>		
	Electrical endurance	The frequency and the expected operation times?	<input checked="" type="checkbox"/>		
	Contact material	Which material?		<input checked="" type="checkbox"/>	
	Contact resistance	How much and the testing conditions?		<input checked="" type="checkbox"/>	
Coil	Rated voltage	How much, direction?	<input checked="" type="checkbox"/>		<ul style="list-style-type: none"> ● the ambient temperature ● the power fluctuation ● Suppression component to coil peak voltage
	Coil resistance	How much? The input power consumption?	<input checked="" type="checkbox"/>		
	Operate voltage	How much? The influence of the power wave?		<input checked="" type="checkbox"/>	
	Release voltage	How much? The influence of the power fluctuation?		<input checked="" type="checkbox"/>	
	Max. allowable voltage	How much? How long?		<input checked="" type="checkbox"/>	
	Coil peak inverse voltage	Size, Internal or external suppression?		<input checked="" type="checkbox"/>	
Performance	Enclosure type	Unenclosed type, dust protected, flux proofed, or plastic sealed?	<input checked="" type="checkbox"/>		<ul style="list-style-type: none"> ● the ambient atmosphere ● the safety requirements
	Dielectric strength	How much? where?	<input checked="" type="checkbox"/>		
	Insulation resistance	How much where?		<input checked="" type="checkbox"/>	
	Vibration resistance	How much?		<input checked="" type="checkbox"/>	
	Shock resistance	How much?		<input checked="" type="checkbox"/>	
Practical Environment	Ambient temperature	High or low? How long?	<input checked="" type="checkbox"/>		<ul style="list-style-type: none"> ● insulation level ● method of encapsulation ● the life
	Atmosphere	Humidity? Harmful gases ?		<input checked="" type="checkbox"/>	
Outline And Mounting	Outline	Size and dimension	<input checked="" type="checkbox"/>		<ul style="list-style-type: none"> ● the required mounting size ● mounting method
	Type Of Terminals	PCB, QC?	<input checked="" type="checkbox"/>		
	Welding mode	Manual solder, wave solder, reflow solder ? Is cleaning needed or not?		<input checked="" type="checkbox"/>	
	Mounting gap	Cling or with gap?		<input checked="" type="checkbox"/>	
Others	Security certification	UL、VDE、TUV、CQC and so on		<input checked="" type="checkbox"/>	<ul style="list-style-type: none"> ● zone ● the customers' requirements
	Special requirements and conditions	The requirements of the customers		<input checked="" type="checkbox"/>	

The following will give the further explanation about the items in the table above.



1 Contact

1.1 Contact Load

Before ensuring whether the load the relay can carry in order to meet with the application, we should confirm the type of the real load except for confirming the load value. The normal load type and wave form for automotive relays are as in table 5.

GUIDELINES OF AUTOMOTIVE RELAY

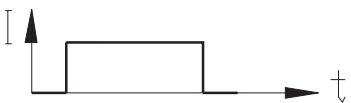
Table 5

The Type Of Load	The Wave Of Current	Load Examples
Resistive load		seat heating, rare window heating, etc.
Inductive load		cooling fans, etc.
Capacitive load		Headlights, fog light, etc

1.2 Contact Material

For the same type of relay, the different contact material is applicable to different load types or ranges. Seen in table 6.

Table 6

Material	Feature	Typical Application
AgNi 0.15	<ul style="list-style-type: none"> ● high electrical conductivity and thermal conductivity ● bad fusion-soldering resistance performance ● easily produce the sulfured film in the atmosphere with sulfid. 	● Resistive load
AgSnO ₂ (with other oxide matter)	<ul style="list-style-type: none"> ● excellent anti-adhesive performance ● the standard material of most of the contact material ● easily produce the sulfured film in the atmosphere with sulfid. 	● Resistive load, lamp load, inductive load and capacitive load
Special AgSnO ₂	<ul style="list-style-type: none"> ● very little material transfer ● easily produce the sulfured film in the atmosphere with sulfid. 	● Flasher

Notes:

- 1) Consider the maximum current value specified in different relays.
- 2) It would better be checked and tested in application when the conditions are catalogue allowable.
Gold plating of the contacts shows good performance for the low loads. However, for the high load, it can only keep the initial contact performance of the contacts before the relays are used.

1.3 Electrical Endurance

Unless otherwise specified, the electrical endurance in the instruction refers to the standard value under rated load in the circumstance that:

- a) Downwards PCB terminals
- b) Separated installation

Considering the flux-proof and the dust-proof types have longer electrical endurance than the sealed type of the same relay with the load of more than 2A, it is preferred to select the flux-proof and the dust-proof types if possible.

For the electronic vacuum pump load, its working reliability and safety factor requirements are high, especially for the application of independent vacuum pump, it is recommended to use SSR (solid state relay) to control the electronic vacuum pump load. If you need to use an electromagnetic relay to control an independent vacuum pump, please consider multiple relays for redundant design. Please contact Hongfa for more technical support.

1.4 Mechanical Endurance

Unless otherwise specified, the mechanical endurance in the instruction refers to the standard value under rated load in the circumstance that:

- a) no contact load
- b) Rated frequency of operation, duty factor 50%
- c) Downwards PCB terminals

2.1 Voltage

To make the relay work reliably, be sure that work circuit can supply the rated voltage to the coil.

Sometimes to shorten the operating time, the coil can be applied to maximum allowable voltage to the coil in the short time. However it should be ensured that the relay will not overheat or even be damaged.

For polarized relay and relays with diode paralleled to coil, please specify the polarity of coil voltage.

GUIDELINES OF AUTOMOTIVE RELAY

2.2 Coil Resistance

To make the relay work reliably, be sure that work circuit supplies the nominal coil power consumption to the relay. Therefore please select the suitable coil resistance.

3 Performances

3.1 Enclosure Type

To ensure the reliability of the relay, different ways of encapsulation will require different post-processing (table 7).

Table 7

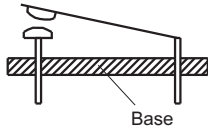
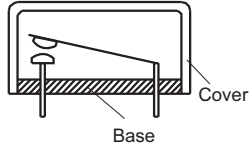
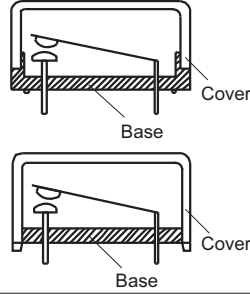
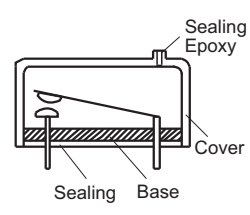
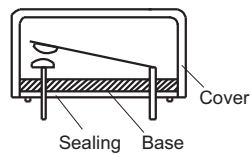
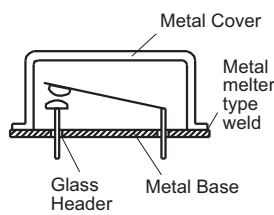
Type	Construction	Features	Auto- matic Solder	Auto- matic Clean- ing	Dust Resis- tance	Liquid Proof	Harmful Gas Resis- tance
Un- enclosed		Without the protective case	X	X	X	X	X
Dust Protected		With the dust protective case; the case and the base are fitted together and their joint is close to PCB.	X	X	√	Δ	X
Flux Proofed		The terminals are plastically sealed on the base or the base and the terminals are fitted with sealing epoxy; the fitted joint is far from PCB. Without exceeding the scheduled position, the flux will not penetrate the relay.	√	X	√	Δ	X
		Base, terminals and case are fitted with sealing epoxy; there is ventilating hole far from PCB. Without exceeding the scheduled position, the flux will not penetrate the relay.	√	X	Δ	Δ	X
Plastic Sealed*		Base, terminals and case are fitted with sealing epoxy; The internal of the relay is sealed in the case and base. Washable in limited condition.	√	Δ	√	√	√
Sealed or Hermetically		Metal case and metal base are sealed; terminals and base are sealed with glass. The leakage rate of the air in the internal of the relay meet with the requirements.	√	√	√	√	√

GUIDELINES OF AUTOMOTIVE RELAY

Notes:

- 1) “√” means good; “×” means not good; “Δ” means to notify.
- 2) Because the plastic has the certain leakage, please use hermetic relays in the conditions that there are harmful gases or the explosive proof is required.
- 3) * Hongfa recommends to implement washing-free soldering process to avoid washing on relay, ultrasonic cleaning is prohibited. If water cleaning or surface treatment is required after the relay is assembled on PCB, please provide with the conditions in details for our confirmation or our recommendation with suitable products.

3.2 Dielectric Strength And Insulation Resistance

Since the electrical system inside car is usually with low voltage, so the requirement for these two parameters are relatively low. Under normal circumstances, it can meet the requirements of use; but for applications in other fields, these two parameters need to be specially confirmed, and will not cause breakdown, short circuit, etc. of the line.

3.3 Vibration Resistance And Shock Resistance

Please confirm that these two parameters can meet the application requirement and will not lead to the failure of the relay in the course of the application.

4 Practical Environment

4.1 Ambient Temperature

Generally speaking, when the temperature does not exceed beyond temperature range speculated in the catalogue, the relay can normally work. When the temperature in application is higher than the temperature speculated in the instructions, please contact Hongfa to ensure whether the relay can be normally used according to the loads.

4.2 Atmosphere

In the atmosphere with high humidity, moisture, even freezing dew and much dust, such as relay applied in engineering, mining, agriculture and other fields, or relay with mounting frame installed outside electrical box, recommend to use sealed relays for the high humidity easily accelerates the rust of the relay parts and the dust easily result in the failure of the relay contacts.

In the atmosphere with organic silicon, unsealed relays shall not be used for the organic silicon will accelerate the failure of the contacts. In the atmosphere with moisture and harmful gases as H₂S、SO₂、NO₂ etc., the flux proofed and dust protected products can not be applied while the plastic sealed products can be used and tested in application.

In application, if the ambient atmosphere is better, recommend to use the dust protected and flux proofed relays for they can get the longer electric endurance than plastic sealed relays.

5 Outline And Mounting

5.1 Outline And Mounting Gap

The outline sizes of the relays usually have a certain tolerance. Therefore when the circuit and the mounting gap are designed, the design is suggested to be done according to the maximum size in the instructions.

5.2 Welding Methods



Since July 1st, 2006, the terminals of the relays produced have been lead-free. The suggested welding temperature and time are respectively $(250 \pm 3) ^\circ\text{C}$, $(5 \pm 0.3)\text{s}$.

If reflow solder is required, it shall be confirmed the relay can be reflow soldered according to the instructions. If you have questions, please contact Hongfa.

5.3 The Model Of The Terminals

Select the suitable shapes of the terminals and mounting methods according to the real conditions.

Table 8

Classification	PCB (THT)	QC(ISO)	QC (280)
Terminals type			
Representative products	HFKA HFKC	HFV6 HF3501	HFV9 HFV11

GUIDELINES OF AUTOMOTIVE RELAY

Table 9

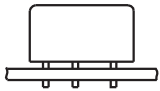
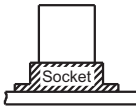
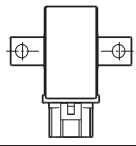
Classification	PCB Mounting THT	Plug-in Mounting	Screw installation
Mounting type			
Representative products	HFKA HFKC	HFV6 HF3501 HFV9 HFV11	HFV12 HFV19

6 Others

Except for normal products, we accept the customer's order for the products with special specifications. Please contact Hongfa where required.

CHAPTER 3 PRECAUTIONS FOR APPLYING THE RELAYS

To properly use the relay, when the relay is selected and its characteristics are learnt, the precautions for using are required to know about to ensure the reliable operation of the relay.

The following precautions will be considered in application:

- 1) The automotive relays are specially designed for automotive application usage. If you are willing to choose automotive relays for other applications, please get contact with Hongfa first.
- 2) All parameters listed on catalogues are separately tested values, relay couldn't satisfy the overlapped test together for many different parameters at the same time.
- 3) The relays are used within the range of the parameters listed in the catalogue to the extent that it is possible.
- 4) Please don't apply on contacts with load that surpasses the rated value, otherwise it may lead to failures such as contact welding, bad connection and even relay burning.
- 5) Please don't apply on relay coil with voltage that surpasses the maximum allowed value, otherwise it may lead to coil overheating, short circuit and even burning.
- 6) The rated load and the life are the referent values, which will be different due to the different environments, load features and types. Therefore they should be tested in the practical or stimulated application.
- 7) Please don't remove the relay cover or do further treatment on relay terminals, otherwise the relay performance couldn't be guaranteed.
- 8) To maintain the performances of relays, please do not make the relay drop or be shocked strongly. Do NOT use relays that have dropped, or potential malfunction might be caused.
- 9) Relays are used in the ambient temperature and normal humidity and in the atmosphere with less dust and harmful gas. The harmful gases include gases with sulfur, silicon and nitrogen oxide etc.
- 10) The relay coil should be driven by input wave of rectangle shape.
- 11) For the latching relays, please set them in the operate or reset state before they are used. Please pay attention to polarity and pulse width when energizing on the coil.
- 12) For polarized relay, please notify the polarity (+, -) of the coil voltage.
- 13) Except for the above there are other precautions. In the following they will be described one by one in the order listed in table 4.

1 Precautions For The Contacts

Contacts are the most important elements of relay construction. Contact life is influenced by contact material, voltage and current value applied to the contacts (especially the voltage and current waveforms at the time of application and release), the type of load, switching frequency, ambient atmosphere, form of contact and the contact bouncing etc. The material transfer, welding, abnormal usage and the increase in contact resistance bring about the failure of the contacts. Please pay attention to them in application.

In order to better apply the relay, please refer to the following precautions for the contacts.

1.1 The Load

The resistive load value is usually listed in the catalogue, however, which is not enough. It should be checked and tested in the practical contact circuit.

The minimum load described in the instructions is not the standard lower limit value the relay can switch reliably. The reliability of this load value is different due to differences of the ON-OFF frequency, the environment, the change of the required CR and absolute values.

GUIDELINES OF AUTOMOTIVE RELAY

1.1.1 Voltage

When the inductive circuit is switched off, there are the reverse voltage which is higher than the electrical circuit. The higher this voltage is the more the energy is. Correspondently the contact wear and material transfer also increase. Therefore notify the load type and load value the contacts of the relay control.

For DC current, the electrical arc extinguishes when the contact gap is up to the certain value. Therefore the duration of the arc is longer than that in AC current and the contact wear and material transfer increases.

For DC load, the higher the contact voltage is, the bigger contact gap will be needed in order to extinguish the electrical arc. Under the same load current, the contact gap needed for switch 24V load is far bigger than that needed to switch 12V load. If using relay marked with 12V to switch 24V load, it may lead to relay burning due to unopened electrical arc. So please only use relay marked with 24V load for 24V application.

For most of the case, the coil voltage for automotive relays is the same as load voltage. But if the coil voltage is different with load voltage (for example the coil voltage is 12V, but the load voltage is 24V), please get contact with HONGFA.

1.1.2 Current

When the contacts are on or off, the inrush currents will greatly influence the contacts. For example, when the load is motor load or lamp load, the higher the inrush current when the contact is on, the more the contact wear and the material transfer increase, and the more easily lead to the contact weld and not to separate. Please check in practical application.

Under the condition of low current during contact make and break (under 2A, especially some loads with higher reverse electromotance, such as magnetic valve and electromagnet coil), the contact reliability will decrease since the contact cleaning effect generated by open & close arc is not obvious. Please contact Hongfa to get

1.2 Precautions For The Application

1.2.1 Avoiding Switching Both The Large Load And The Micro Load In The Same Relay

When switching the high load, the scattered contact material is produced, which will attach to the contacts with the low load and lead to the failure of the contacts. Therefore, please avoid the same relay switching both the high load and the low load.

1.2.2 Precautions For The Two Pairs Of Contacts Connected In Parallel

When the two pairs of contacts are connected in parallel, the reliability will be improved but the load capacity could not for the two pairs of contacts could not be broken or closed at the same time.

1.2.3 Electrical Endurance In The High Temperature

Electrical endurance of the relay will be lower in the high temperature than that in the low temperature. Please check while it is operating in the actual application.

1.2.4 Connection Of Multiple Pairs Of Contacts And The Load

Multi-contacts are arranged in the same polarity of the supply power to the extent that it is possible and the passive polarity in the other polarity of the supply power, as shown in figure 4 (a). Thus, the short circuits between the contacts, due to voltage differences between the contacts, can be possibly avoided. The wiring as shown in figure 4 (b) can be avoided.

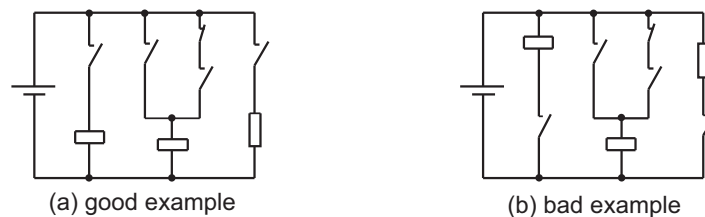

Figure 4

GUIDELINES OF AUTOMOTIVE RELAY

1.2.5 Avoid Short Circuit Caused By Contacts Weld And Electrical Arc

In the electrical circuit, the following points should be considered (seen in the figure 5)

1) Generally the gap between the contacts are small. The reason can probably be that the electrical arc between the contacts results in the short circuit. Please do not adopt the circuit shown in figure 4(b). The circuit shown in figure 3(a) is suggested to use and the certain interval can be set in the operation between Con1 and Con2.

2) Care should be taken that the two pairs of switching contacts are not used to build the forward circuit and the reverse circuit, as shown in figure 5(d). We recommend to use electrical circuit demonstrated in pic 5 (c), but please don't apply over-current on contact to prevent short circuit from happening on NO, NC contacts due to unopened electrical arc which may lead to short circuit on electrical power supply.

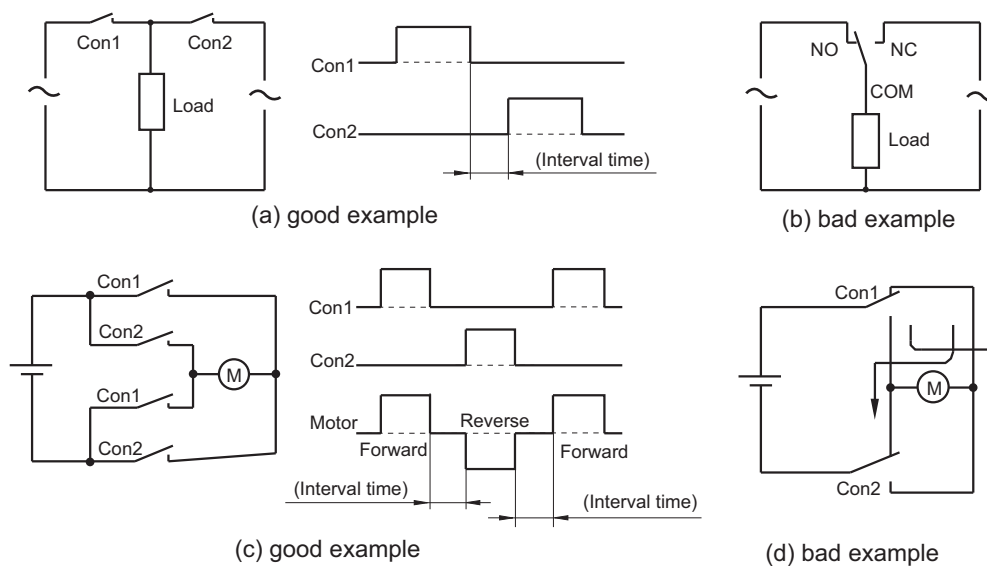

Figure 5

1.2.6 Precautions for the contacts of the magnetic latching relays

Generally the latching relays are shipped from the factory in the reset states. However during shipping or mounting the relays the shock to the relay may change to the operate state. Therefore suggest that in application it be set in the required state.

In the course of using, latching relay state (set or reset) may change when it is subjected to strong impact or severe vibration. Therefore, it is suggested that corresponding protection measures should be designed in the circuit. For example, monitoring the state of the relay contact, it can make the relay return to the desired state in time under an abnormal condition.

1.3 Contact Protection

1.3.1 Inrush Current And The Reverse Voltage

When the motor, capacitance, solenoid and lamp load make, the inrush current is generated, which is several times of the rated current. When the inductive load such as solenoid, the motor, contactor, the reverse voltage which are from hundreds of to thousands of volts.

Both inrush current and the reverse voltage will damage greatly the contacts and obviously shorten the life of the relay. Therefore the proper use of the contact protection circuit may increase the life of the relay.

1.3.2 Material Transfer Of Contacts

The material transfer phenomenon of the contact refers to the transfer of the contact material on one side to the contact on the other side. When the material transfer is severe, the unevenness of the contact surface can be seen with the naked eye, as shown in Fig. 6, this kind of unevenness is easy to cause contact adhesion.

GUIDELINES OF AUTOMOTIVE RELAY

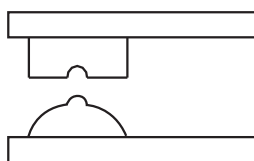

Figure 6

Generally, material transfer of contacts is caused by the one-way flowing of the large current or the inrush current of the capacitive load and often happens in DC circuit. Therefore the proper use of the contact protection circuit or the use of AgSnO₂ contact which has better resistance against material transfer may reduce the material transfer of contacts. The AC load with large capacity should be checked in actual application in the test.

1.3.3 The Protective Circuit Of The Contacts

Generally speaking, in contrast to resistive load, inductive load more easily damages the contacts. The use of properly protective circuit may make the influence of inductive load on the contacts equal to the influence of resistive load on the contacts. Care is taken that the incorrect use will generate the counter effect. Table 10 shows the typical examples of the contact protective circuit.

Table 10

Circuits Example	Appli- cation (DC)	Featrues	Device Selection
CR Circuit 	√	<ul style="list-style-type: none"> ● The supply voltage is usu. 24 to 48V. ● The load is a timer or a contactor, the release time lengthens ● If the load is a time, leakage current flows through the CR circuit causing faulty operation. 	A: As a guide in selecting C and R C: 0.5 to 1μF per 1A contact current R: 0.5 to 1Ω per 1V contact voltage Values vary depending on the properties of the load and variations in relay characteristics; Please check by test. Capacitor C acts to suppress the discharge the moment the contacts open. The dielectric strength of the capacitor C is usu.200V to 300V.
	√	<ul style="list-style-type: none"> ● Applicable to the supply voltage of 100 to 200V ● If the load is a relay or a contactor, the release time lengthens. 	
Diode Circuit 	√	<ul style="list-style-type: none"> ● At the terminals of the inductive load the diode is connected in parallel, which can reduce the reverse voltage. ● The release time is longer than that in CR circuit. 	Select a diode with the reverse breakdown voltage at least 10 times the circuit voltage and a forward current at least as large as the load current.
Diode And Zener Diode Circuit 	√	<ul style="list-style-type: none"> ● If the zener diode is added in the diode circuit the release time is reduced. 	Use a zener diode with a zener voltage about the same as the supply voltage.

GUIDELINES OF AUTOMOTIVE RELAY

To be continued

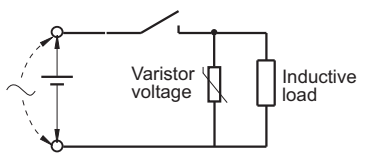
Circuits Example	Application (DC)	Features	Device Selection
Piezo Resistance Circuit 	√	<ul style="list-style-type: none"> ● Reduce the excessively high voltage between the contacts ● If the load is a timer and a contactor, the release time lengthens 	Use the piezo resistance with control voltage V_c 1.5 times the supply voltage peak value. If the control voltage is excessively high, the effect of the reverse control is not good.

Notes: the mark "√" means good. Please avoid to use the following circuit as table 11.

Table 11

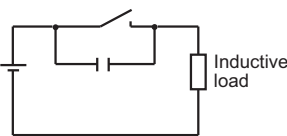
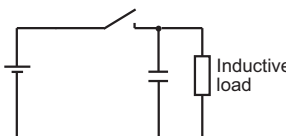
	
When the contacts are OFF, the effect on controlling the electric arc is good. However in this case the capacitor C stores the energy, so the energy in the capacitor C will release to the contacts, when the contacts are ON, will result in the easy welding of the contacts.	When the contacts are OFF, the effect on controlling the electric arc is good. However the contacts are easily welding due to the large charge current of the capacitor C when the contacts are ON.

1.3.4 Precaution For mounting Protective Elements

When the protective elements such as diode, C-R, piezo resistance are mounted, they must be mounted beside the load or the contacts. If the distance is far, the protective effect will not be good. Suggest that they are mounted within 50cm.

1.4 Inspection

Since the automotive relays are supposed to be used to switch relay load inside cars and the real currents inside cars are usually relatively big (usually bigger than 1A), the voltage is usually 12V or 24V. So if using smaller current and contact voltage to do inspection on relay contact, it usually will lead to wrong judgment. And if contact status need to be changed during inspection (from pick-up to drop-out or vice versa), please ensure the contacts could reach the set condition and are stabilized, otherwise it may also lead to wrong judgment. HONGFA recommend to use inspection voltage and current bigger than 6Vd.c., 0.1A to do inspection for contacts. If the contacts status need to be changed, HONGFA recommend to delay a time period 15 times that of pick-up time (applicable for operation from drop-out to pick-up) or drop-out time (applicable for operation from pick-up to drop-out) before doing inspection.

2 Precautions For The Coil

The application of rated voltage to the coil is based on which the relay works normally. Only applied the voltage beyond the operate voltage, the relay can work, but the rated voltage must be applied to the coil for the changes caused by the temperature and the variation of the power voltage will influence the normal operation of the relay. To make sure contacts can make and break load current with reliability, the duration time that when voltage is applied on coil of monostable relays should be longer than 100ms and The duty cycle should be less than 50%.

The automotive relays are mostly voltage driven type, we suggest to choose products with standard voltage specifications as listed on catalogue, if relays with other voltage specifications are needed, please get contact with Hongfa engineer for confirmation.

2.1 Polarities

Normally the automotive relays don't need to specify coil voltage polarity, but if restrain diode are assembled inside relay, the relay coil voltage polarity must be confirmed. If the coil voltage direction is wrong, it may lead to burn of diode due to short circuit. Please pay great attention to this point.

2.2 Maximum Allowable Voltage Of The Coil

Except for the limits from the coil temperature rise and the heat-resistant temperature of insulation material of the coil electro-magnetic wire (once beyond the heat-resistant temperature, short circuit will locally happen in the coil and even the coil burns), the maximum allowable voltage of the coil will be influenced by heat distortion and the aging of the insulation materials. Especially it can not destroy other machines, hurt the human body or cause the fire, so it must be limited with the certain range. Therefore please do not make it beyond the regulated value in the instructions.

Maximum allowable voltage is the maximum value of the voltage which can be applied to the coil of the relay rather than the value allowed to continuously be applied.

2.3 The Coil Temperature Rise

2.3.1 Temperature Rise

In the course of the relay operation, the coil will raise its temperature. When a pulse voltage with ON time of less than 2 minutes is used, the coil temperature rise value is related to the ON time and the ratio of ON time to OFF time. The various relays are essentially the same in this aspect. (table 12)

Table 12

(Current Passage Time)	(%)
For Continuous Passage	Temperature Rise Value Is 100%
ON:OFF=3:1	about 80%
ON:OFF=1:1	about 50%
ON:OFF=1:3	about 35%

2.3.2 Pick-up Voltage Change Due To Coil Temperature Rise

The temperature rise causes the increase of the coil resistance and correspondently the pick-up voltage will increase. the resistance temperature coefficient of the copper wire is about 0.4% per 1°C . with this ratio, the coil resistance increases. Pick-up, release and reset voltages in the instructions are all the values in 23°C .

When the coil temperature is beyond 23°C ,pick-up voltage surpasses sometimes the speculated value in the catalogue. Please check in the practical application.

2.4 Leakage Current

When designing the circuit, please avoid the leakage current flowing through the relay when the relay does not work.

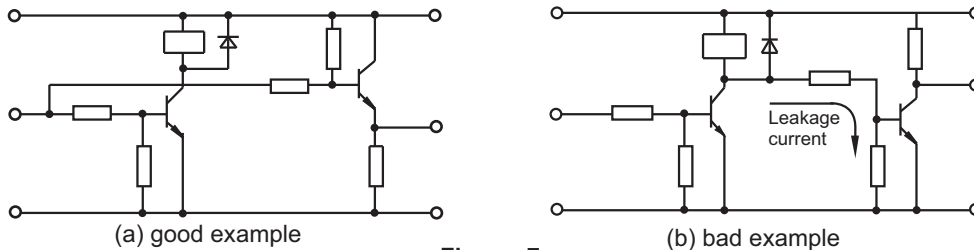

Figure 7

2.5 Energized Voltage Of The Coil And Operation Time

Although the voltage applied to the coil increases and operate time of the relay will properly become rapid, the contact bounce time when the contacts closes is extended to cause the reduction of the life or the contacts welding when they work in the rated load or in the large inrush current.

2.6 Coil peak inverse voltage

Since the relay coil is inductive load, when relay coil circuit is opened, the over voltage will be produced on both sides of the switch by the stocked energy in coil. The peak value of over voltage may reach several KVs. Also the faster the open speed is, the higher the overvoltage will be. If the anti-voltage performance of the semi-conduct components that control coil circuit is not good enough, the components may be breakdown. Also the peak inverse voltage will be conducted through power supply wire, which may cause severe electrical magnetic disturbance.

For 12V system, the coil peak inverse voltage usually needs to be controlled below 100V or 150V. The typical coil peak inverse suppression circuit is as shown in figure 8.

GUIDELINES OF AUTOMOTIVE RELAY

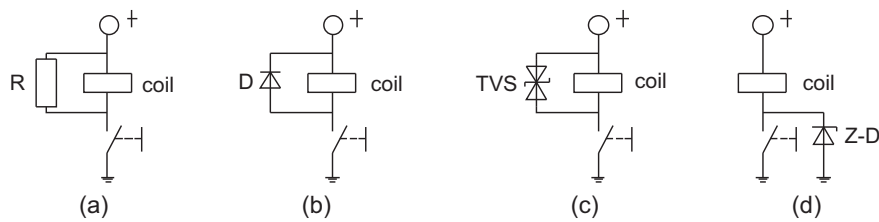

Figure 8

After the coil control switch is opened, the electrical circuit will be formed by suppression components together with coil, which will slow down coil current decreasing speed, and also slow down the move contact returning speed. The relay endurance life will be decreased through this process. The coil peak inverse voltage suppression circuit shown in pic 8(b) is with the best suppression performance, but the relay endurance life will be hugely decreased also, so we normally don't recommend. For QC relays, we recommend to use products with coil paralleled with resistor. For PCB relays, we recommend to use electrical circuit as shown in pic 8 (d). Please pay attention to polarity of the coil driving voltage when relay coil is paralleled with diode as shown in figure 8(b), to avoid short circuit and breakthrough on diode.

2.7 The Application Of The Relays Connected In Parallel And In Series.

Several relays connected in parallel, please take care of the wrong operation for the bypass current and leakage current shown as figure 9.

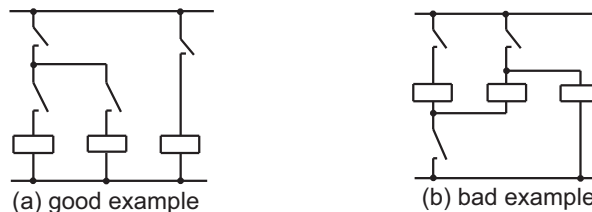

Figure 9

2.8 Avoid Gradual Increase Of Coil Impressed Voltage

In the course of the operation, the relay experiences such phases as contact pressure changing, contact bounce and the unstable condition of the contacts. When gradual increase of coil impressed voltage happens, the time of the unstable phase becomes longer to affect the life of the relay.

In order to reduce the influence on the relay, please impress bypass voltage to the coil, to the extent that it is possible.

2.9 Long Term Current Carrying

If the coil is continuously applied the power to for a long term, the self heating of the coil promotes the aging of the insulation materials of the coil and the worse characteristics, so in this case please use the latching relay. If the monostable relay must be used, please use the hermetic relay which is not easily influenced by the external environments and also use the suitably protective circuit to prevent the loss due to the contact failure or the break of the coil wire.

2.10 Low ON-OFF Frequency

When the ON-OFF frequency is below once per month, please periodically check the make states of the contacts. If the contacts keep the non ON-OFF state for a long time, the organic film will be formed on the surface of the contacts to result in the contact failure of the contacts.

2.11 Precaution For The Coil Of The Magnetic Latching Relays

2.11.1 The Coil Voltage

Please check whether the direction of coil impressed voltage is correct or not, do not apply voltage to both the set coil and reset coil. or the relay may not work. In order to ensure the latching relay's set or reset, the excitation voltage of the coil must reach the rated voltage. The voltage pulse width is recommended to be 50 ms to 100 ms.

Due to the characteristics of the magnetic latching relays, to prevent the relay against overheating and then burning. The long-term impressed voltage (>1min) on the coil are not allowable.

2.11.2 Self-locking Of The Relays

Please avoid using the NC contacts of the relay itself to switch off its own coil. Otherwise the failure will happen due to the instability of the relay operation. (Figure 10)

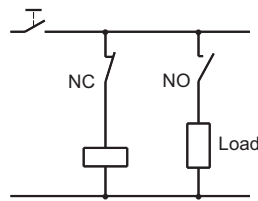

Figure 10

2.11.3 Precautions For Using The Relays Connected In Parallel

When the coil of the latching relay is connected in parallel with the coil and the solenoid of other relays, please add diode to prevent the reverse voltage from influencing the normal work of the relay.

2.11.4 Width Of Minimum Impulse In Operating And Resetting

In order to make the latching relay operate or reset, please impress the rectangle rated voltage for more than 5 times the operate time or the reset time on the coil and then operate it. If the impulse width can not meet the requirements above, please check in the actual application.

Please avoid using them in the conditions that the power source has many surges.

2.11.5 Precautions For The Double-Coil Relay

Do not impress the voltage on the set coil and reset coil at the same time, or the relay will abnormally heat, abnormally operate and even abnormally wear.

As shown in figure 11, when the terminals of either of operate coil and reset coil in the circuit are required to connect and the other terminals are connected to the same polarity of the power source, Please directly connect the terminals to connect (short circuit) and then connect to the power source. Thus the insulation between the coils can be maintained well.

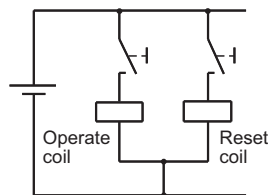

Figure 11

3 Performance

3.1 Vibration And Shock

The transient break of the contacts when the relays are shocked strongly, will lead to the false operation. Therefore, when the relays are mounted on the same board with other parts (such as electromagnetic switch, air switch et.) which can produce the shock, the measures of reducing the influence of the shock on the relay should be taken. For example, make the direction of the shock

3.2 Vibration, Shock And Weight During Shipping

During shipping the relay or the equipment with the relay installed, the large vibration, shock and weight will cause the failure of the relay functions. Please use the cushion package to control the vibration and shock within the allowable range.

4 Environments

4.1 The Harmful Gases To The Relay

Please do not use the relay in the atmosphere with the following gases. In these atmospheres, plastic sealed relays can not avoid the influence of these gases on the contacts. Please use the hermetic relays.

4.1.1 Silicon Atmosphere

Silicon-based substances (silicon rubber, silicon oil, silicon-based coating material and silicon caulking compound etc.) around the relay will emit volatile silicon gas, which may cause the silicon to adhere to the contacts and may result in contact failure.

GUIDELINES OF AUTOMOTIVE RELAY

4.1.2 Sulfureted Gas

Sulfured gases easily sulfur the contacts and result in the contact failure or non-conduction.

4.1.3 NO_x Gas

When a relay is used in an atmosphere high in humidity to switch a load which easily produces an arc, the NO_x created by the arc and the water absorbed from outside the relay combine to produce nitric acid. This corrodes the internal metal parts and adversely affects operation. Please do not use the relay in the atmosphere where the humidity is beyond 85%RH (at 20°C).

4.2 External magnetic field

Please don't use relay in environment with strong external magnetic field, otherwise it may lead to malfunction. and change the parameters of latching relay, such as set and reset status. Plus, due to influence of magnetic field, when contact load is off, the electrical arc between contacts may be bent and let to problems such as bad insulation.

4.3 Atmosphere Of Usage, Storage And Transport

During usage, storage and transportation, avoid locations subject to direct sunlight and maintain normal temperature, humidity and pressure conditions. The allowable range of the temperature and humidity suitable for usage, storage and transportation are shown in the unshaded part in figure 11. The allowable temperature may differ with the different types of the relays.

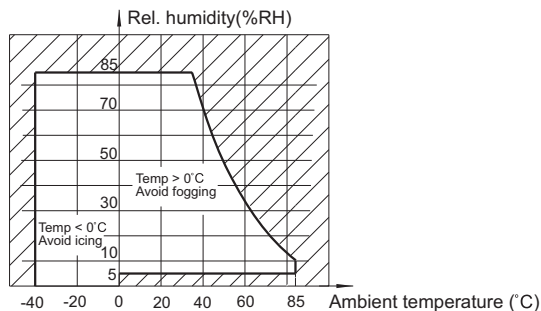

Figure 12

The suggested ranges of the temperature and humidity during usage, transportation and storage are as follows.

- 1) temperature: 0°C to 40°C
- 2) humidity: 5%RH to 85%RH
- 3) air pressure: 86kPa to 106kPa.

4.3.1 Storage

The storage time of the relay refers to the product in stock before being loaded into the complete machine. In general, for relays that require wave soldering or reflow soldering, the solderability of the terminals of the relay can be tested after 6 months of storage (take the production date of the relay as the starting date). Qualified products can still be installed and used, but generally it should not exceed 18 months. Pay attention to the storage environment during the process; for non-wave soldering and non-reflow soldering relays, the electrical parameters of the relay can be tested once after storage for 12 months (starting with the production date of the relay) and qualified. The product can still be installed and used, but generally should not exceed 36 months. Pay attention to the storage environment during the process.

4.3.2 The Atmosphere High In Humidity

In the atmosphere high in humidity, when the temperature around sharply changes, the dew will be formed in the internal of the relay and result in the cracking of the insulation material, the break of the coil wire and the rust. The typical examples will happen on the ship transporting on the sea.

Dewing is a phenomena that the vapor freezes water drops in the atmosphere high in temperature when the temperature sharply reduces from the high temperature to the low temperature or the relay is moved in the high temperature from the low temperature

4.3.3 Low Temperature (under 0°C) Environment

Please note the icing phenomena in the environment with low temperature (under 0°C). Icing may result in the welding of the movable parts, the delay of the operation or preventing the operation etc.

Icing refer to the phenomena that water attached to the relay will freeze ice when the temperature reducing below freezing point.

4.3.4 Low Temperature , Low Humidity Environment

Note that the plastics may embrittle in low temperature, low humidity environment.

4.3.5 High Temperature, High Humidity Environment

Note that if the relay is in high temperature, high humidity environment for a long time the contact surface easily forms the oxidized film and then results in the unstable contact and the failure of the contacts. Other metal parts also are easily oxidized or rusted to result in the failure of the functions

5 Outline And Mounting

5.1 Top View And Bottom View

Generally the bottom view is the projection whose projection plane is terminal side. Otherwise, the top view is the projection whose projection plane is cover side. Please take care of it when using the instructions or mounting the relays.

5.2 Mounting Direction

Unless otherwise stated, mounting direction of the relays is arbitrary. In order that the relay can work more stable and reliable, mounting direction need cosidering.

5.2.1 Vibration Resistance And Shock Resistance

It is ideal to mount the relay so that the movement of the contacts and movable parts is perpendicular to the direction of vibration or shock. Especially when the coil is not excited, the vibration or shock resistance of NC contacts is weak. If mounting direction is proper, their functions can be ensured. (figure 12).



Figure 13

5.2.2 Contact Reliability

Mounting the relay so the surfaces of its contacts are vertical prevents dirt and dust as well as scattered contact material and powdered metal from adhering to them when the arc is generated.

5.3 Adjacent Mounting

When many relays are mounted close together, abnormally high temperatures may result from the combined heat generated. To prevent the heat buildup, please mount relays with sufficient spacing between them.

When many boards mounted with relays are installed in a card rack, please be sure that the ambient temperature of the relay does not exceed the value listed in the instructions.

5.4 Bracket Mounting

Use the gaskets when mounting to prevent from the damages and deforms. The tightening torque should be within (0.49~0.686) N · m or (5~7) kgf · cm. To prevent from loosening, please use the spring gasket.

5.5 Mounting The Plug-In Relay

Before installing the relay, if the female terminal used has a B-type structure and has a blocking function, it should be fully confirmed whether the blocking function is completely matched with the blocking hole of the plug-in relay and installed in place, otherwise it may cause electrical contact failure; if When using female terminals without locking function, it is recommended to use plug-in relays without locking holes at the terminals to match them to improve the reliability of electrical contact.

GUIDELINES OF AUTOMOTIVE RELAY

After installing the relay, in principle, it is not allowed to pull out and use the relay twice. If the relay has to be used twice, it is necessary to fully evaluate and confirm whether the clamping force of the female terminal meets the standard requirements to ensure the reliability of electrical contact; When pulling out the relay, use a special pull-out tool (see Figure 14(a)) and pull it out perpendicular to the top of the relay. The process should not pull out the relay diagonally (see Figure 14(b)) or use a similar utility knife or screwdriver. (See Figure 14(c)) and other tools to pry the relay from the socket, otherwise it will cause terminal skew and electrical contact failure.

When installing the relay, it is forbidden to use rubber hammer, rubber rod and other objects to knock the relay, otherwise there is a risk of damage to the relay (see picture 14 (d)). To ensure reliability of relay assembly, semi-automatic or automatic pressing with pneumatic and positioning devices is recommended (see picture 14 (e)). Refer to Figure 14(f) for normal position of relay contacts; refer to Figure 14(g) for abnormal position after relay is knocked.

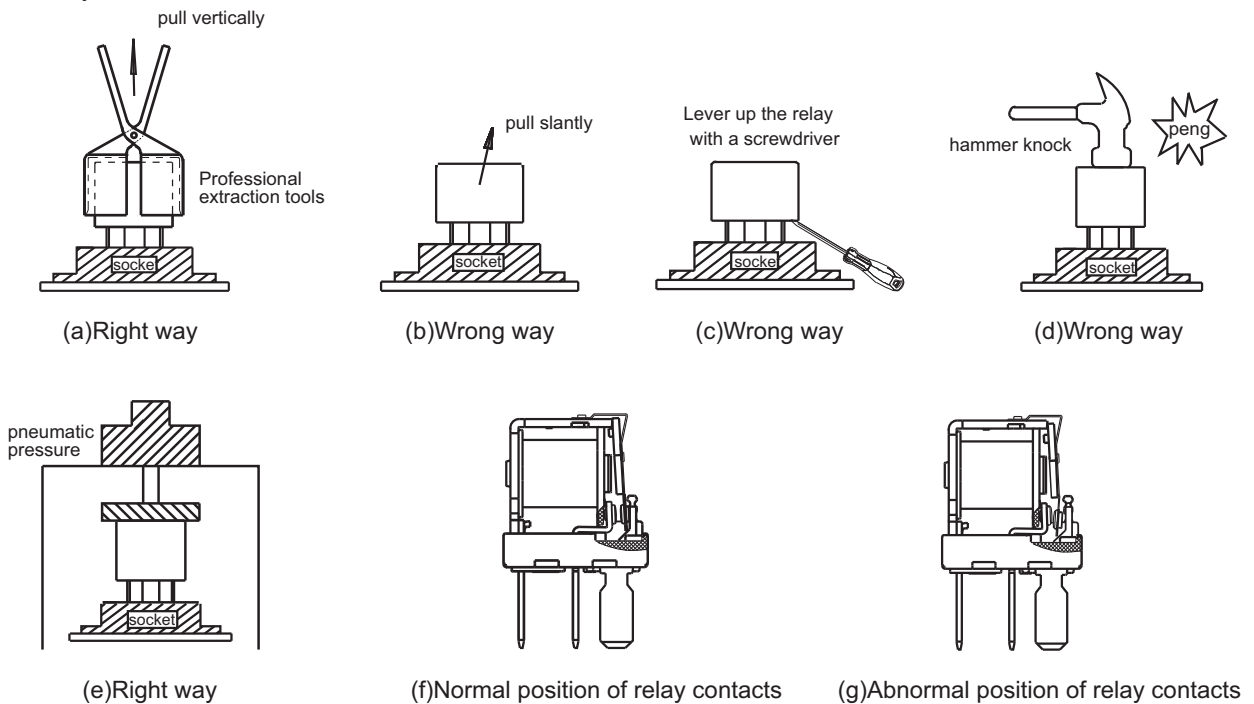

Figure 14

5.6 The diameter of conduction wire

The diameter of conduction wire that assembled with relay should be decided by load current. If the conduction wire diameter is too small, it may lead to extreme high temperature rise and even burning. We suggest to choose conduction wire basing on table 13.

Table 13

PCB Current A		Rigid and flexible conductors
Min (excluding)	Max(including)	Cross sectional area mm ²
-	3	0.5
3	6	0.75
6	10	1.0
10	16	1.5
16	25	2.5
25	32	4.0
32	40	6.0
40	63	10

5.7 Mounting And Soldering Of THT Relays

The mounting and soldering of the THT relay can be divided into the following steps.(figure 14)

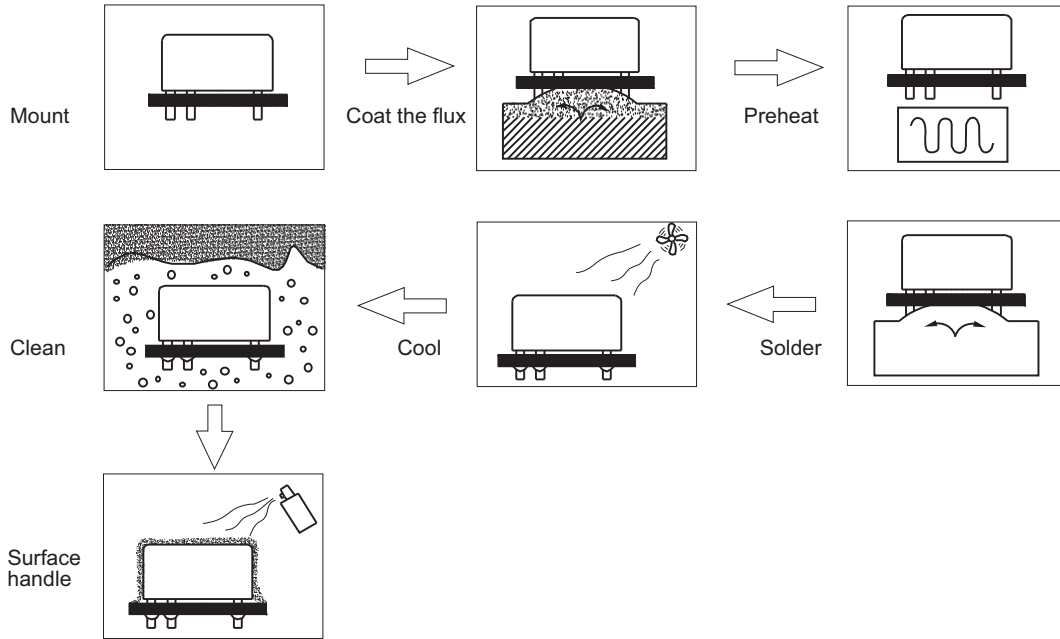

Figure 15

In the following the considered points are described when THT relay is soldered on the PC board. Please refer to them in application.

Note that if the solder entered the relay due to the carelessness, the functions of relay will be destroyed. There will be such problems as the relay not suitable for the automatic soldering or cleaning due to the different protective constructions. Please see the details in the constructions and characteristics in 3.1 pattern of encapsulation in Chapter 2.

5.7.1 Mounting

Do not bend the terminals of the relay (figure 16) for it may destroy the initial performances of the relay.

Please correctly process the PC board according to the mounting hole drawing in the instructions.

Please maintain the balance of the relay.

Please note that the set force of the hook for mounting is too much large to result in the internal failure of the relay.(Please refer to 5.8.2 for clamp force)

Before installation and after installation, it is forbidden to cut off or disassemble the terminal of the relay. Otherwise, the initial performance of the relay may be damaged.

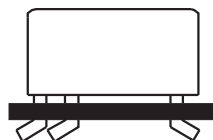

Bad example

Figure 16

GUIDELINES OF AUTOMOTIVE RELAY

5.7.2 Coating Flux

Please use the rosin flux which is not corrosive and the alcohol solvent which is less chemistry.
 Please use the thin and even coating flux to prevent from penetrating the relay. As for the dipping coating, please keep the surface of the flux stable.
 Please adjust the places to ensure that the flux will not overflow through the surface of PCB.
 Please do not make the flux attached to the parts of the relay except for the terminals. Otherwise the insulation of the relays will be reduced.
 For the dust protected relays and flux proofed relays, do not use the coating method of pushing deeply PCB from the above into the sponge absorbing the flux, as shown in figure 17. This will make the flux penetrating the relay, especially for the dust protective type.

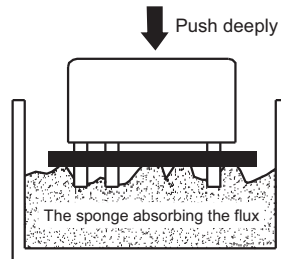

Figure 17

5.7.3 Preheating

In order to improve the soldering performance, please preheat without fail.
 Please preheat under 100°C (the soldered surface of the PC board) within 2 minute.
 Do not use the relays which are placed in the high temperature for a long time due to the set failure for their initial performance may have changed.

5.7.4 Soldering

Precautions for soldering seen in table 14.

Table 14

Automatic Soldering	Manual Soldering
<ul style="list-style-type: none"> ● To maintain the soldering stable, the suggested soldering method is wave solder. ● Adjust the height of flux liquid level to make them not overflow the PCB. ● Please do it according to the following suggested conditions. Soldering temperature: $(260 \pm 3)^{\circ}\text{C}$ Soldering time: $(5 \pm 0.3)\text{s}$. 	<ul style="list-style-type: none"> ● Please sufficiently clean the head of searing-iron with fluxing to make the surface of it smooth. ● Please do it according to the following suggested conditions. Searing-iron: 30W or 60W The temperature of the head of searing-iron: about 280°C or 300°C Soldering time: within about 3s Use the solder with rosin fluxing.

Disassembling or repeated welding of welded relay would result in coil wire breaking or performance change, please prevent repeated welding of relay during usage.

5.7.5 Cooling

After automatic soldering, please ventilate and cool them to avoid the aging of the relay or its parts caused by the heat generated when the relay soldered.

5.7.6 Cleaning

Please select the cleaning method in table 15 when cleaning.

Table 15

Dust Protected Type	Flux Proofed Type	Plastic Sealed Type
<ul style="list-style-type: none"> ● Hot cleaning or soap cleaning not allowable ● Scrub the welding surface of PCB 		<ul style="list-style-type: none"> ● Washable in limited condition. ● Use the alcohol solvent or water. ● The temperature for cleaning is under 40°C. ● Do not do supersonic cleaning or truncate the terminals of the relays, or the break of the coil wire and the contact welding will happen.

GUIDELINES OF AUTOMOTIVE RELAY

Due to different soldering condition, sealed relays can be impaired when mounting on PCB. If cleaning is necessary after soldering, it is recommended to solder under the condition provided by HF and to select special sealed relays (customer code: 310).
Avoid cleaning with Freon, Trichloroethane, diluent or gasoline.

5.7.7 Surface Handling

In order to prevent the insulation of PCB from worsening, please note the following precautions when surface handling.

The dust protected type and the flux proofed type result in the failure due to the surface handling agents penetrating the relay. Therefore please As far as possible do the surface handling or mount the relay after surface handling. Due to the bad influence of the surface handling agents on the relay eg.melting the cover, Therefore, please contact Hongfa for more technical support before surface treatment.

If the PCBA surface has to be treated, the distance between the surface treatment agent and the relay should be > 5mm, as shown in Figure 18.

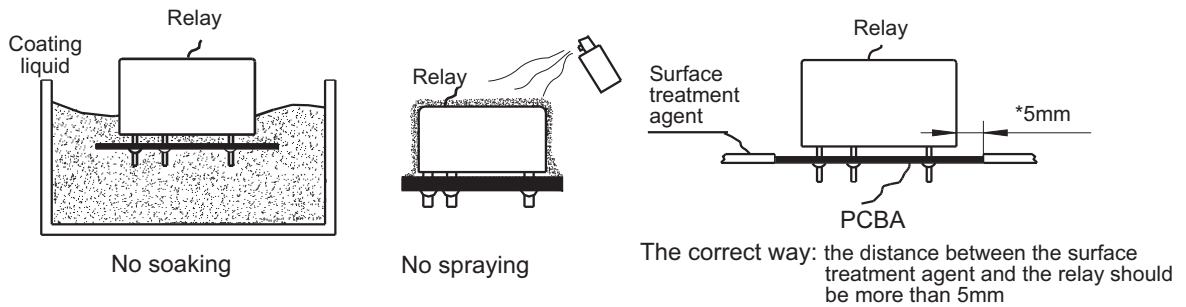

Figure 18

Spraying and brushing processes are recommended for surface treatment, and dip-coating is prohibited. Surface treatment agent should best be room-temperature liquid agent, which should be sprayed when the relay is cooled down to room-temperature. The agent can be dried naturally or under constant temperature which should not exceed 60°C. Meanwhile, the drying temperature is not allowed to be decreased when the agent is not completely dried, otherwise the agent could be absorbed into the relay and thus lead to relay failure.

No surface treatment coating which contains organosilicone is allowed on relay surface and surroundings. There are the following suggestions on the coat, as shown in table 16.

Table 16

Type Of The Coat	Plastic Sealed Relay
Epoxy resin	Allowable
Polyurethane	Allowable
Silicon	Not allowable
Fluorin	Allowable

5.8 Mounting And Soldering Of PIP Relays.

The mounting and soldering of PIP automotive relays have the following steps, as shown in figure 19. In the following the considered points are listed when the SMT relays are soldered on PCB.

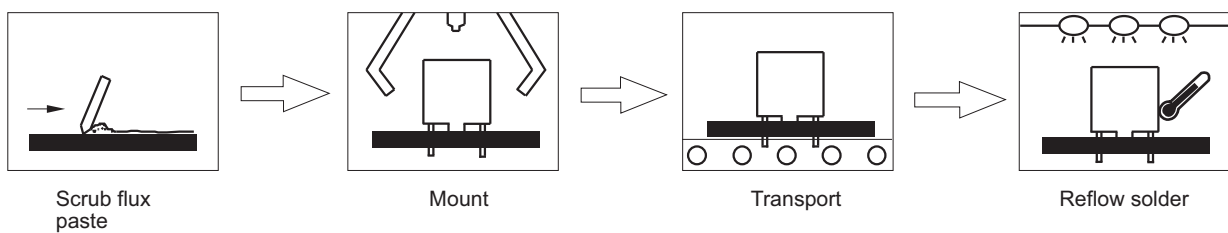

Figure 19

Please refer to these in application. Note that the relays are not damaged in processing.

GUIDELINES OF AUTOMOTIVE RELAY

5.8.1 Scrub Flux Paste

Please use the rosin and chlorin-free flux paste for chlorin may erode the terminals and circuit panel.

5.8.2 Mounting

If the gripping force of mechanical arm is too big, the relay internal structure will be damaged during assembly, and the relay performance will be influenced.

The clamp force for the gripper from Direction A to Direct E should be $\leq 9.8\text{N}$ when relay is being mounted; please avoid force concentration; force area of single side gripper should be bigger than 6mm^2 .

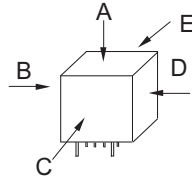

Figure 20

5.8.3 Transportation

During the transport, the relays will not fall off due to the factors such as the shock and vibration to avoid the bad soldering produced thereby.

5.8.4 Reflow Solder

Figure 21 shows the temperature curve of the PCB surface when the infrared ray are used to reflow solder. Please consult the specification of the relays due to the different characteristics of the different relays. If there is no statement in the instructions, Please use the temperature curve as shown in the following figure.

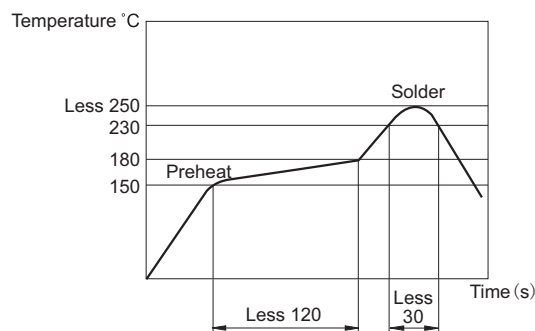

Figure 21

Since the vent hole of the PIP automotive relays will not be sealed beforehand but normally assembled with flux during soldering. Washing or surface treatment on relay after soldering is prohibited.

Disassembling or repeated welding of welded relay would result in coil wire breaking or performance change, please prevent repeated welding of relay during usage.

5.9 Cutting PCB

- When the relay is welded to the PCB and the PCB is scuttled, PCB should be fixed firmly, cut short cutting time, reduce vibration to avoid coil breakage caused by relay vibration;
- Epoxy dust may occur when cutting PCB board, Dust entering into the relay will cause poor contact of relay contacts. The appropriate package type of relay should be evaluated;
- PCB should not be broken, otherwise it may damage the initial performance of the relay.

6 Other Precautions

6.1 Precautions For The Safety

When the relay works, do not touch the relay with hands for there is the danger of getting the electric shock.

Please switch off the power when mounting, maintaining and handling the relays (including the connecting parts such as terminals and sockets).

When connecting the terminals, firstly refer to the wiring diagram in the instructions, and then make correct connection. The false connection may result in the unexpected false operation, abnormal heating or fire.

If the contact welding, the failure of the contact or the break of the coil wire happens, other properties or lives will be threatened. Please use the double mounting sets.

6.2 Tube Packaging

When packing the relay by the tube, do not shake the tube to shock the relays, for which will result in the failure of the relays. If the package uses the stop plug, be sure to slide the stopper plug to hold the remaining relays firmly together so they would not move in the tube.

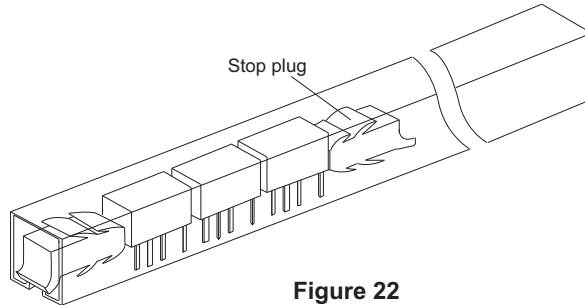

Figure 22

6.3 Bad feedback

Please do not disassemble relays. If failure is found during application, return relays to Hongfa for further analysis and issue identification.

CHAPTER 4 ORDERING CODE

Ordering code contains the basic information of the relays. Table 17 shows the typical marks of Hongfa relays. The specific model of the ordering code is referred to the specification.

		HFKA /		012	-1Z	S	P	T	(XXX)
Type	HFKA: Standard HFKA-T: Reflow soldering version High-temperature version								
Coil voltage	012: 12VDC								
Contact arrangement	1H: 1 Form A (Single version) 2H: 2 Form A (Twin version) 1Z: 1 Form C (Single version) 2Z: 2 Form C (Twin version)								
Construction	S: Plastic sealed ⁽¹⁾	Nil: Flux proofed							
Coil power	P: Low pick-up voltage	Nil: Standard							
Contact material	T: AgSnO ₂								
Customer special code⁽²⁾	XXX: Customer special requirement						Nil: Standard		

- Notes:**
- 1) Contact is recommended for suitable condition and specifications if water cleaning or surface process is involved in assembling relays on PCB.
 - 2) In environments with high humidity, moisture, or even condensation, and dust, such as relays used in engineering, mining, agriculture and other fields, or relays with mounting brackets installed outside of electrical boxes, it is recommended to use plastic-encapsulated products; in environments containing phosphorus, H₂S, SO₂, NO₂ and other harmful gases, plastic-encapsulated types must be used and tested and confirmed in actual use; in environments containing organic silicon, please avoid using dust-proof covers;
 - 3) The performance parameters of products with characteristic numbers shall be subject to the specific specifications provided by Hongfa.

GUIDELINES OF AUTOMOTIVE RELAY

CHAPTER 5 QUICK ZOOM TABLE FOR REASONS FOR FAILURE

Some common failure phenomena, failure modes, and the reasons. See table 18:

Table 18

Failure Phenomena	Failure Mode	Failure Reason
Non-operation	No current at the terminals of the coil	<ul style="list-style-type: none"> ● Breaking circuit ● Worse connected or short circuit ● Terminal welded worse
	Insufficient voltage in the circuit	<ul style="list-style-type: none"> ● Insufficient voltage supply ● Power circuit too long ● the voltage of the chosen relay too high
	Circuit unconnected	<ul style="list-style-type: none"> ● Welded failure ● Coil breaking
	Relay failure	<ul style="list-style-type: none"> ● Drop, bumped badly ● Contact failure
	Voltage polarity of the polarized relay is wrong	<ul style="list-style-type: none"> ● Bumped during the transportation ● circuit connected badly
No Release	Surplus voltage too high	<ul style="list-style-type: none"> ● Energy storage component's influence ● Leakage current or bypass current ● Surplus voltage of the semiconductor too high
	Relay failure	<ul style="list-style-type: none"> ● Drop, bumped badly ● contact failure
Unsteady Operation	Unsteady power	<ul style="list-style-type: none"> ● PARD(periodic and random deviation) ● Insufficient voltage ● Resistor beyond the tolerance
	Unsteady parameter	<ul style="list-style-type: none"> ● Drop or bumped badly ● Short form among the coils
	False operation of the relay	<ul style="list-style-type: none"> ● Something wrong with the control procedure ● The vibration excessively strong in application
NC/NO Contact Welding	Current excessively high	<ul style="list-style-type: none"> ● Load excessively high ● Surge current too high
	Contact Moving abnormally	<ul style="list-style-type: none"> ● External vibration excessively strong ● Unstable operation
NC/NO Contact Welding	Operation frequency excessively high	
	Ambient temperature excessively high	
	Use beyond the life	
NC/NO Contact Not Closed	Contact resistance too high	<ul style="list-style-type: none"> ● Weld failure ● Contamination in the contact ● Bad using environment, contact oxidizing or sulphidizing
	No current in the contacts surface	<ul style="list-style-type: none"> ● Load circuit break ● Circuit connected worse or short circuit ● Terminal welded worse
	Used beyond the life limit	

Notes: when failure happens, if there's any question, please contact us.